

900 Series Buccaneer®

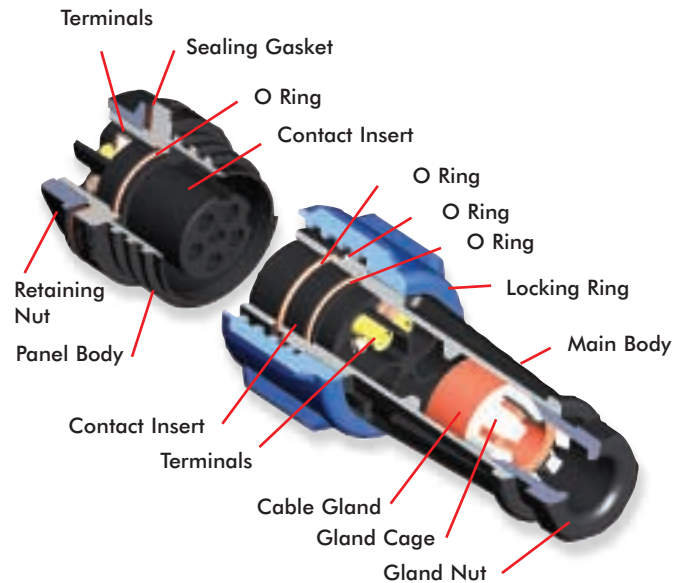

IP68



- IP68 rating tested at 1.054Kg/sq cm (15lb/sq in) 10m depth for 2 weeks
- 32A, 600V ac/dc rating
- 2, 3, 4, 5 and 7 pole
- Plug or socket connection in each body style
- Water and dustproof to IP68 when mated
- 'Scoop proof' contacts
- Field termination - screw terminations
- Positive locating keyways - cannot be mis-connected
- Sealing caps available to maintain IP68 rating of unmated connectors
- Leading earth contact for 3, 4, 5 and 7 pole versions
- Trailing Neutral on 5 pole
- Compact design
- Easy assembly - no special tools required
- Single or 3 phase applications
- Bulkhead moulding available for use with flange mounting body for 45° or 90° mounting (order each separately)
- Cost effective solution
- Two cable connector versions for 15mm and 22mm cable diameters
- Separate strain relief on large cable version
- UL, CSA and VDE approvals

900 Series Buccaneer®

BUCCANEER

FLEX CABLE CONNECTOR



PX0911



PXA911

- Mates with in-line flex or panel mounting versions
- Positive, fast acting locking ring - can be turned with a gloved hand
- Plug or socket versions
- PX0 Series 13-15mm cable dia. as standard, 7-13mm with additional gland pack
- PXA Series 20-22mm cable dia. as standard, 14-20mm with additional gland pack
- Strain Relief Clamp (PXA Series only)

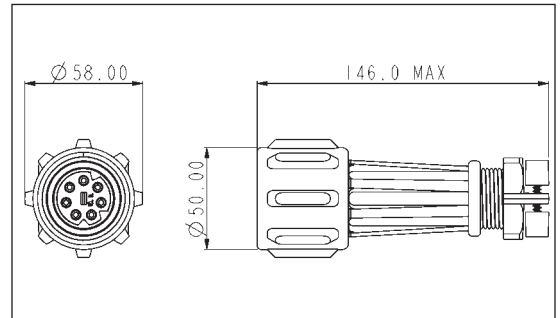
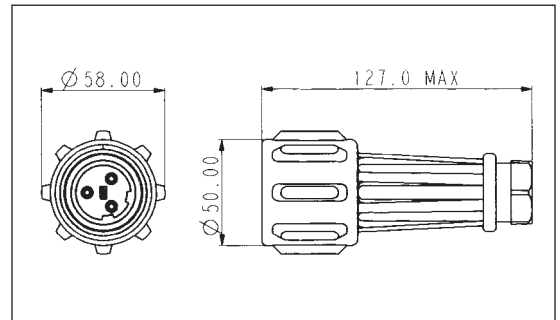

Flex Cable

Standard Cable	Large Cable	Description	Standard Cable	Large Cable	Description
PX0911/02/P	PXA911/02/P	2 pole Plug	PX0911/02/S	PXA911/02/S	2 pole Socket
PX0911/03/P	PXA911/03/P	3 pole Plug	PX0911/03/S	PXA911/03/S	3 pole Socket
PX0911/04/P	PXA911/04/P	4 pole Plug	PX0911/04/S	PXA911/04/S	4 pole Socket
PX0911/05/P	PXA911/05/P	5 pole Plug	PX0911/05/S	PXA911/05/S	5 pole Socket
PX0911/07/P	PXA911/07/P	7 pole Plug	PX0911/07/S	PXA911/07/S	7 pole Socket

IN-LINE FLEX CABLE CONNECTOR



PX0921



PXA921

- Mates with either PX0911 or PXA911 connectors
- Plug or socket versions
- PX0 Series 13-15mm cable dia. as standard, 7-13mm with additional gland pack
- PXA Series 20-22mm cable dia. as standard, 14-20mm with additional gland pack
- Strain Relief Clamp (PXA Series only)

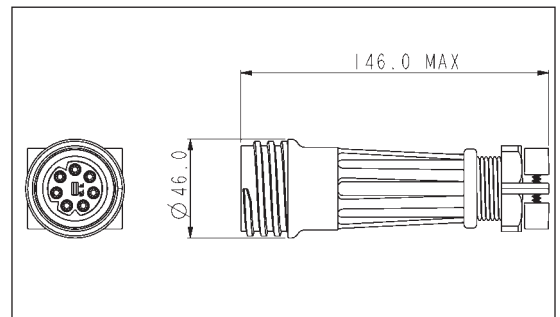
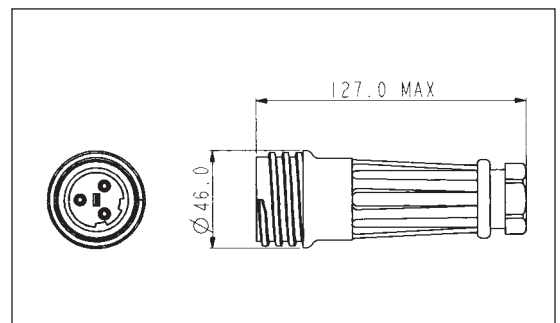

In-Line Flex Cable

Standard Cable	Large Cable	Description	Standard Cable	Large Cable	Description
PX0921/02/P	PXA921/02/P	2 pole Plug	PX0921/02/S	PXA921/02/S	2 pole Socket
PX0921/03/P	PXA921/03/P	3 pole Plug	PX0921/03/S	PXA921/03/S	3 pole Socket
PX0921/04/P	PXA921/04/P	4 pole Plug	PX0921/04/S	PXA921/04/S	4 pole Socket
PX0921/05/P	PXA921/05/P	5 pole Plug	PX0921/05/S	PXA921/05/S	5 pole Socket
PX0921/07/P	PXA921/07/P	7 pole Plug	PX0921/07/S	PXA921/07/S	7 pole Socket

900 Series Buccaneer®

PANEL MOUNTING CONNECTOR



PX0931

- Mates with PX0911 and PXA911 connectors
- Single hole fixing
- Anti-rotation key
- High grade sealing gasket
- 3-7mm panel thickness

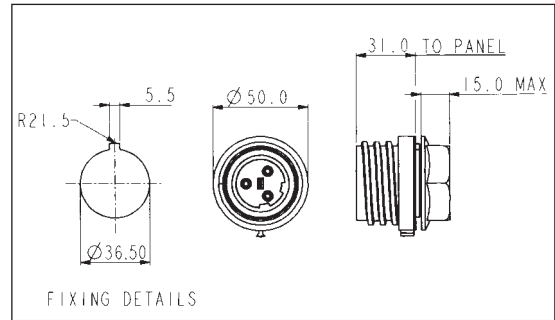

Panel Mounting

PX0931/02/P	2 pole Plug	PX0931/02/S	2 pole Socket
PX0931/03/P	3 pole Plug	PX0931/03/S	3 pole Socket
PX0931/04/P	4 pole Plug	PX0931/04/S	4 pole Socket
PX0931/05/P	5 pole Plug	PX0931/05/S	5 pole Socket
PX0931/07/P	7 pole Plug	PX0931/07/S	7 pole Socket

FLANGE MOUNTING CONNECTOR



PX0941

- Mates with PX0911 and PXA911 connectors
- Supplied with high grade sealing gasket
- Supplied with sealing grommets for panel fixing screws (M6 thread recommended)

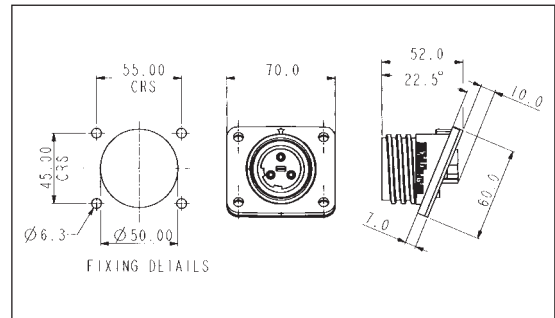

Flange Mounting

PX0941/02/P	2 pole Plug	PX0941/02/S	2 pole Socket
PX0941/03/P	3 pole Plug	PX0941/03/S	3 pole Socket
PX0941/04/P	4 pole Plug	PX0941/04/S	4 pole Socket
PX0941/05/P	5 pole Plug	PX0941/05/S	5 pole Socket
PX0941/07/P	7 pole Plug	PX0941/07/S	7 pole Socket

900 Series Buccaneer®

ADDITIONAL BULKHEAD ADAPTOR MOULDING



PX0950

- For use with flange mounting connector PX0941, to give 45° or 90° angle
- Supplied with high grade sealing gasket
- Supplied with sealing grommets for panel fixing screws (M6 thread recommended)



PX0950 & PX0941

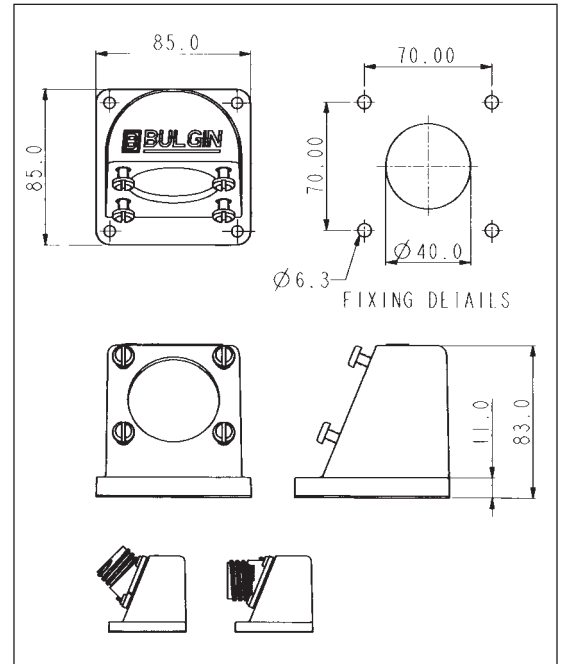

BUCCANEER

ACCESSORIES



PX0960, PX0970

- Sealing caps to maintain IP68 rating of unmated connectors

Accessories

PX0960	Sealing cap for use with PX0911/xx/x and PXA911/xx/x
PX0970	Sealing cap for use with all other styles
PX0980	Pack of 3 additional cable glands for PX0911 and PX0921 to suit cable sizes; 11-13mm, 9-11 and 7-9mm dia.
PXA980	Pack of 3 additional cable glands for PXA911 and PXA921 to suit cable sizes; 18-20mm, 16-18 and 14-16mm dia.

PART NO SYSTEM

PXx9 x x / xx / x / xx

Series Designation
 09 = Standard Cable Accommodation (7-13mm)
 A9 = Large Cable Accommodation (14-22mm)

Body Styles
 1 = Flex, 2 = Flex In-line,
 3 = Panel, 4 = Flange Panel

Contact Termination
 1 = Screw Terminal

Number Contacts
 02 = 2 pole, 03 = 3 pole, 04 = 4 pole,
 05 = 5 pole, 07 = 7 pole

Contact Type
 P = Plug, S = Socket

Cable Acceptance

PX0 version:		PXA version:	
Blank = 13-15mm	Yellow cable gland (standard)	Blank = 20-22mm	Yellow cable gland (standard)
03 = 11-13mm	Black cable gland	09 = 18-20mm	Black cable gland
02 = 9-11mm	White cable gland	08 = 16-18mm	White cable gland
01 = 7-9mm	Dark Grey cable gland	07 = 14-16mm	Dark Grey cable gland

Example:
 PX0911/07/P/03 = Flex cable connector with standard cable accommodation body, seven pin contacts, with gland to suit 11-13mm cable.

900 Series Buccaneer®

SPECIFICATION

Electrical:

No Poles:	2, 3	4, 5	7*
Current Rating:	32A 30A, CSA	32A 25A, CSA	32A
Voltage Rating:	600V ac/dc	600V ac/dc	430V ac/dc
Contact Resistance:	<10mΩ (initial)		
Insulation Resistance:	>10 ⁶ MΩ (@ 500V dc)		
Dielectric strength:	2.2kV ac min		
AC Breakdown voltage:	6kV		
Operating Temperature Range:	-40°C to +85°C		
Approvals:			

*UL and CSA approvals pending for 7 pole

Material:

Body Mouldings:	Polyamide
Flammability Rating:	UL94V-0
UV Resistance:	To EN50021: 1999
Contacts:	Machined Solid Brass, Nickel plated
O Rings:	Nitrile
Panel Sealing Gasket:	Silicone Rubber

Mechanical:

Sealing:	IP68, EN60529 :1992 tested @ 1.054Kg/sq.cm. (15lb/sq.in.) 10m depth for 2 weeks
Cable Acceptance:	PX0911-PX0921 13 - 15mm O/D standard, 7-13mm with gland pack PXA911-PXA921 20 - 22mm O/D standard, 14 - 20mm with gland pack
Contact Accommodation:	2.5 to 4mm ² (13 to 10AWG) conductor, single or multi stranded
Termination:	Axial screw terminals
Cable Retention force:	15mm dia, 150N 7mm dia, 80N
Tightening Torques:	
Panel mount nut	2.25 Nm
Flange & Bulkhead fixing screws	0.9 Nm
Gland Nut Torques:	
PX0 range	
7mm-9mm (grey)	5.42Nm (48 lb/in)
9mm-11mm (white)	5.42Nm (48 lb/in)
11mm-13mm (black)	3.62Nm (32 lb/in)
13mm-15mm (yellow)	3.16Nm (28 lb/in)
PXA range	
14mm-16mm (grey)	5.42Nm (48 lb/in)
16mm-18mm (white)	4.06Nm (36 lb/in)
18mm-20mm (black)	4.06Nm (36 lb/in)
20mm-22mm (yellow)	3.62Nm (32 lb/in)

CONTACT LAYOUT

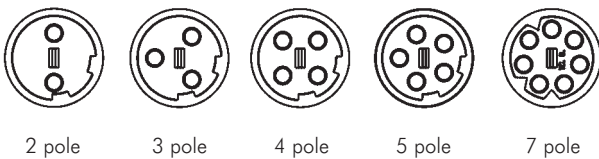

Dimensions:

Overall dimensions of connectors when mated together

PX0911 + PX0921	230 mm max.
PXA911 + PXA921	270 mm max.
PX0911 + PX0931	135 mm max. (to panel)
PXA911 + PX0931	175 mm max. (to panel)
PX0911 + PX0941	145 mm max. (to panel, mid point on flange)
PXA911 + PX0941	174 mm max. (to panel, mid point on flange)